



## MOUNTING INSTRUCTION



PROFESSIONAL e-Board mounting system FLEX

# Mobile height adjustable stand for PROFESSIONAL e-Board

# MOUNTING INSTRUCTION

## Mobile height adjustable stand for PROFESSIONAL e-Board

### English

1. Mounting can only be executed by qualified staff.
2. Warning! Inaccurate mounting can cause injury or damage of the product.
3. Include the inspection of mounting and moveable parts as part of your maintenance procedure.

Note only for chalk/green board surfaces: Before use, please colour the whole enamel chalk surface with white chalk. Afterwards clean with damp cloth and your chalkboard is ready for use.

### German

1. Die Montage darf nur durch qualifizierte Mitarbeiter erfolgen.
2. Achtung! Eine inkorrekte Montage kann zu Verletzungen führen oder das Produkt beschädigen.
3. Ihre Wartungsroutine sollte die Überprüfung aller montierten und beweglichen Teile umfassen.

Hinweis nur für Kreide-/ grüne Tafelflächen: Vor Gebrauch bitte die gesamte emaillierte Tafelfläche mit weißer Kreide bedecken. Anschließend mit einem feuchten Tuch reinigen und Ihre Kreidetafel ist einsatzbereit.

### French

1. Le montage doit être réalisé uniquement par du personnel qualifié.
2. Attention ! Un montage imprécis risque de causer des blessures ou d'endommager le produit.
3. Veuillez à intégrer l'inspection des pièces mobiles et de montage à vos procédures de maintenance.

Note applicable uniquement aux surfaces des tableaux verts (à craie) : Avant usage, recouvrez de craie blanche toute la surface en émail. Essuyez ensuite à l'aide d'un chiffon humide et votre tableau est prêt à l'emploi.

### Dutch

1. De montage mag alleen worden uitgevoerd door vakbekwaam personeel.
2. NB! Onzorgvuldige montage kan leiden tot verwondingen of schade aan het product.
3. Neem de inspectie van de montage en bewegende delen op in uw onderhoudsprotocol.

Opmerking, uitsluitend voor krijt- en groene borden: maak het gehele geëmailleerde krijtoppervlak vóór gebruik wit met krijt. Dan reinigen met een vochtige doek, en uw krijtbord is gereed voor gebruik.

### Spanish

1. El montaje sólo puede ser ejecutado por personal cualificado.
2. ¡Atención! El montaje inexacto puede causar lesiones o daños al producto
3. Incluya la inspección del montaje y de las piezas móviles en su política de mantenimiento.

Nota sólo para uso en superficies de tiza/ pizarra verde. Antes de usarla, coloree toda la superficie esmaltada de tiza con tiza blanca. A continuación, limpie con un paño húmedo y su pizarra estará lista para ser usada.

### Italian

1. Il montaggio può essere effettuato solo da personale qualificato.
2. Attenzione! Un montaggio impreciso può provocare ferite o danneggiare il prodotto.
3. Effettuare l'ispezione delle parti di montaggio e in movimento in base ai criteri di manutenzione.

Solo per superfici di pannelli in gesso/verdi: prima dell'uso, colorare con gesso bianco l'intera superficie in gesso smaltato. Quindi pulire con un panno umido e la lavagna sarà pronta all'uso.

### Swedish

1. Montering får endast utföras av behörig personal.
2. Varning! Felaktig montering kan leda till personskador eller till att produkten går sönder.
3. Låt inspektion av montering och rörliga delar ingå i underhållspolicyn.

Observera rörande skrivtavlor/gröna tavlor: Färglägg hela skrivtavlans emaljyta med vit krita före användning. Rengör sedan skrivtavlan med en fuktig trasa och den är redo för användning.

### Polish

1. Monta powinien wykonywać tylko wykwalifikowany personel.
2. Uwaga! Nieprawidłowe zamontowanie stwarza to ryzyko wypadków lub uszkodzenia sprzętu.
3. W harmonogramie regularnej konserwacji należy przewidzieć przeglądy mocowania i elementów ruchomych.

Tylko w przypadku tablic kredowych i zielonych: Przed użyciem należy zarysować całą emaliowaną powierzchnię do kreślenia za pomocą białej kredy. Po wyczyszczeniu wilgotną szmatką tablica jest gotowa do użytku.











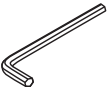
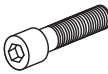
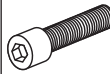
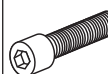
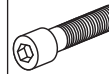
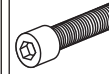

Монтаж может выполняться только квалифицированным персоналом. Внимание! Неправильный монтаж может стать причиной травм или вызвать повреждение изделия. Включите проверку монтажа и движущихся частей в свою программу контроля.

Примечание только для поверхностей досок, предназначенных для писания мелом: Перед применением натрите всю эмалированную поверхность белым мелом. Затем очистите влажной тканью и ваша доска будет готова к применению.



لا يجوز التركيب إلا بواسطة أشخاص مؤهلين. تحذير! التركيب غير الدقيق يمكن أن يتسبب في الإصابة أو في تلف المنتج.

يرجى إخضاع فحص التركيب والأجزاء المتحركة لسياسة الصيانة الخاصة بكم.

ملاحظة خاصة بأسطح الألواح الخضراء أو الطباشير: يرجى قبل الاستخدام تلوين كامل سطح السبورة، المطلي بالمينا، بالطباشير الأبيض، ثم تنظيفه فيما بعد بقطعة منة القماش؛ وبذلك تكون السبورة جاهزة للاستخدام.

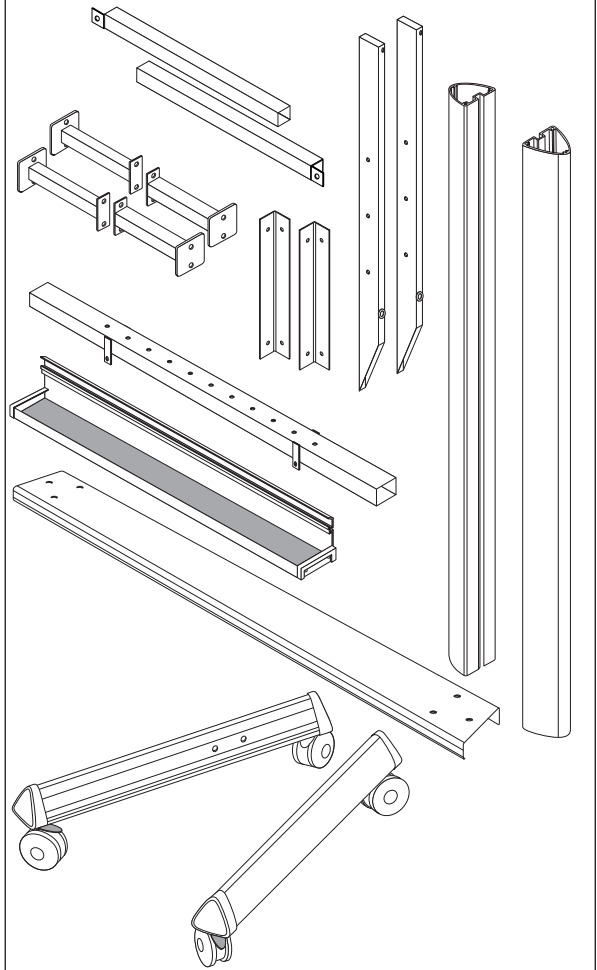
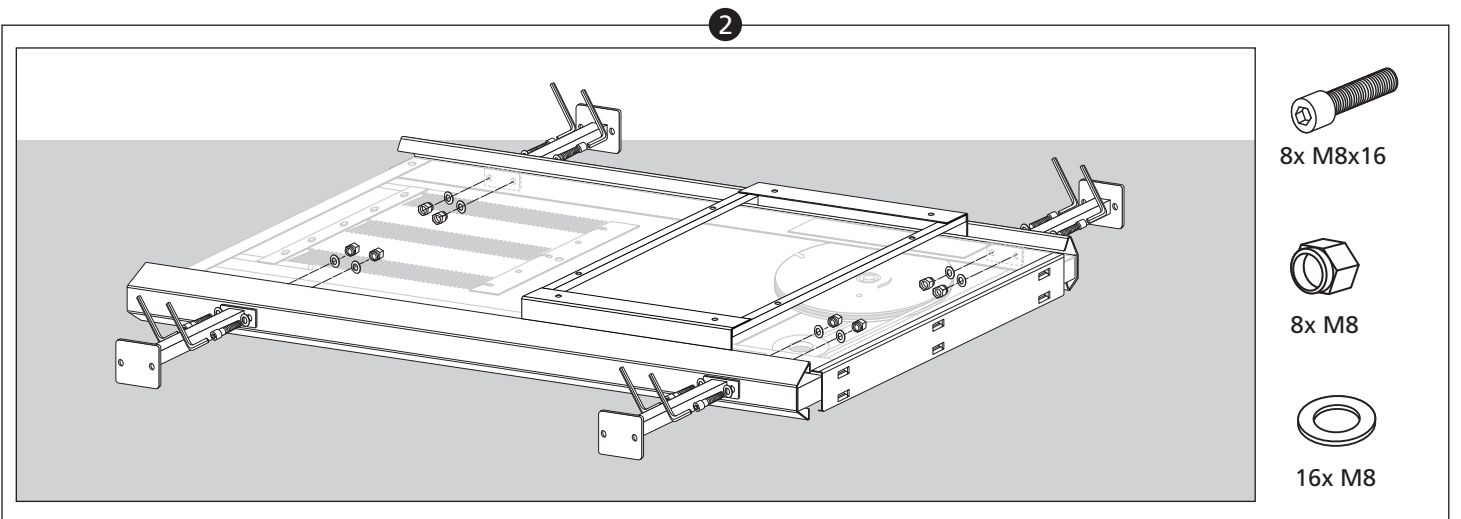
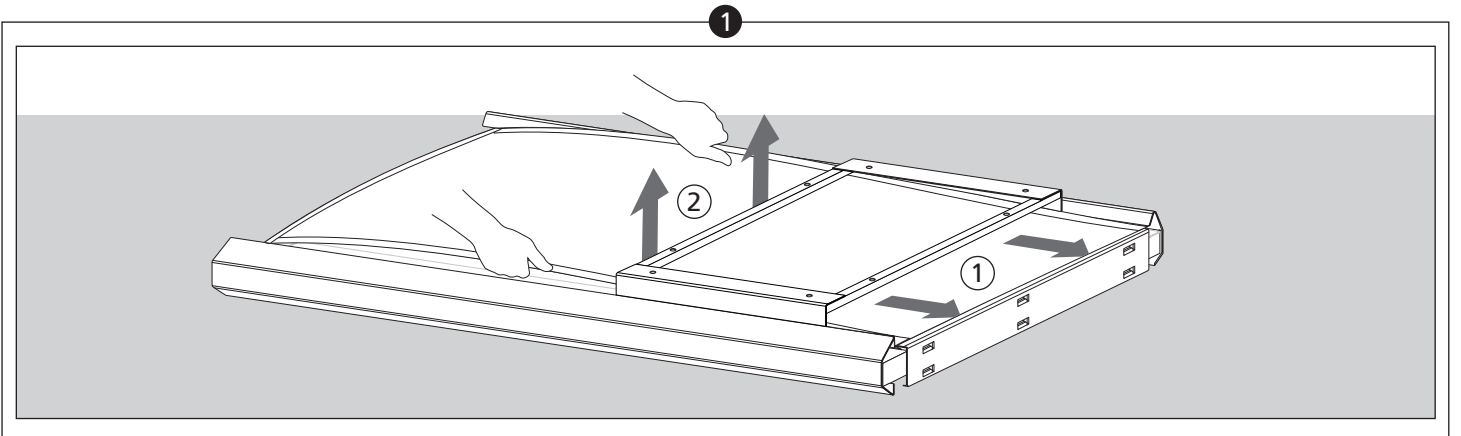
																
2,5 mm	2x M8x80	4x M8x50	10x M8x35	4x M8x30	22x M8x16	44x M8	10x M8	18x M8	2x M6x12	2x M6	2x M6	2x M5	2x M5x6	2x M5x6	4x M8	2x M8

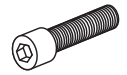

-  8x M8x16
-  8x M8
-  16x M8

# MOUNTING INSTRUCTION

Mobile height adjustable stand for PROFESSIONAL e-Board

3

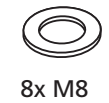
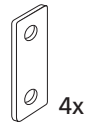
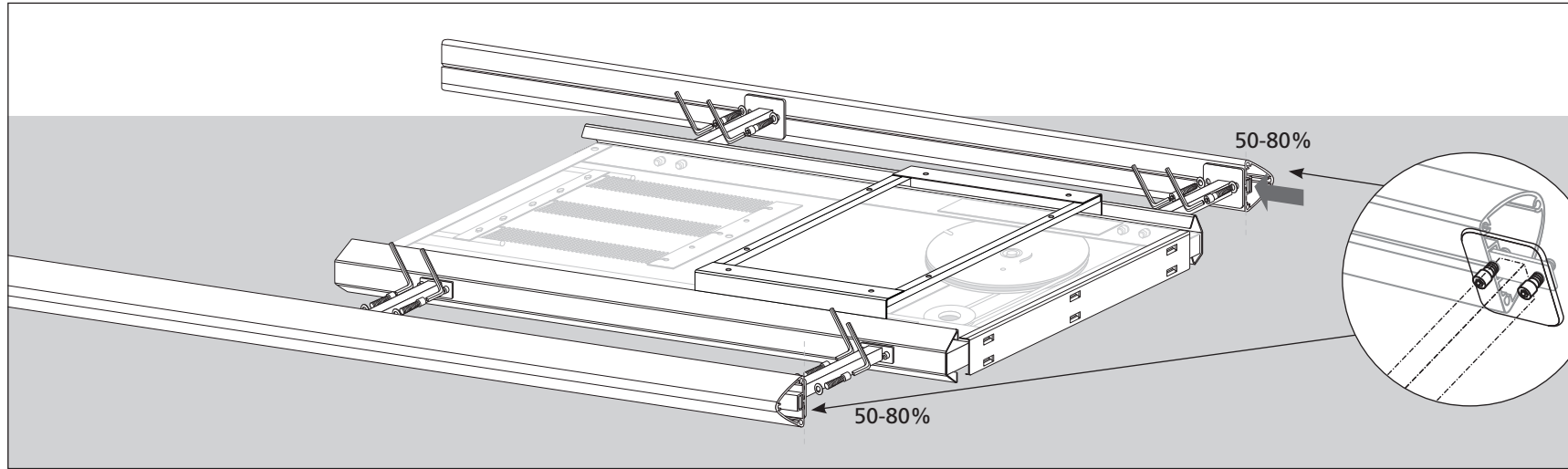

4

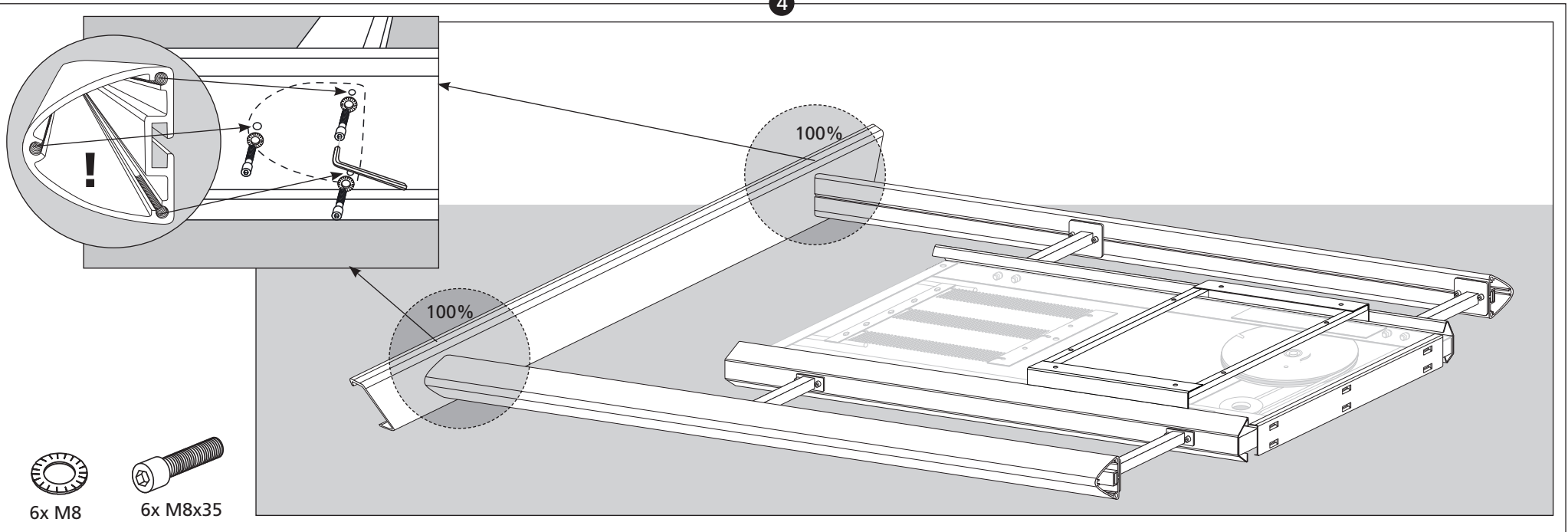

857586000-2

5

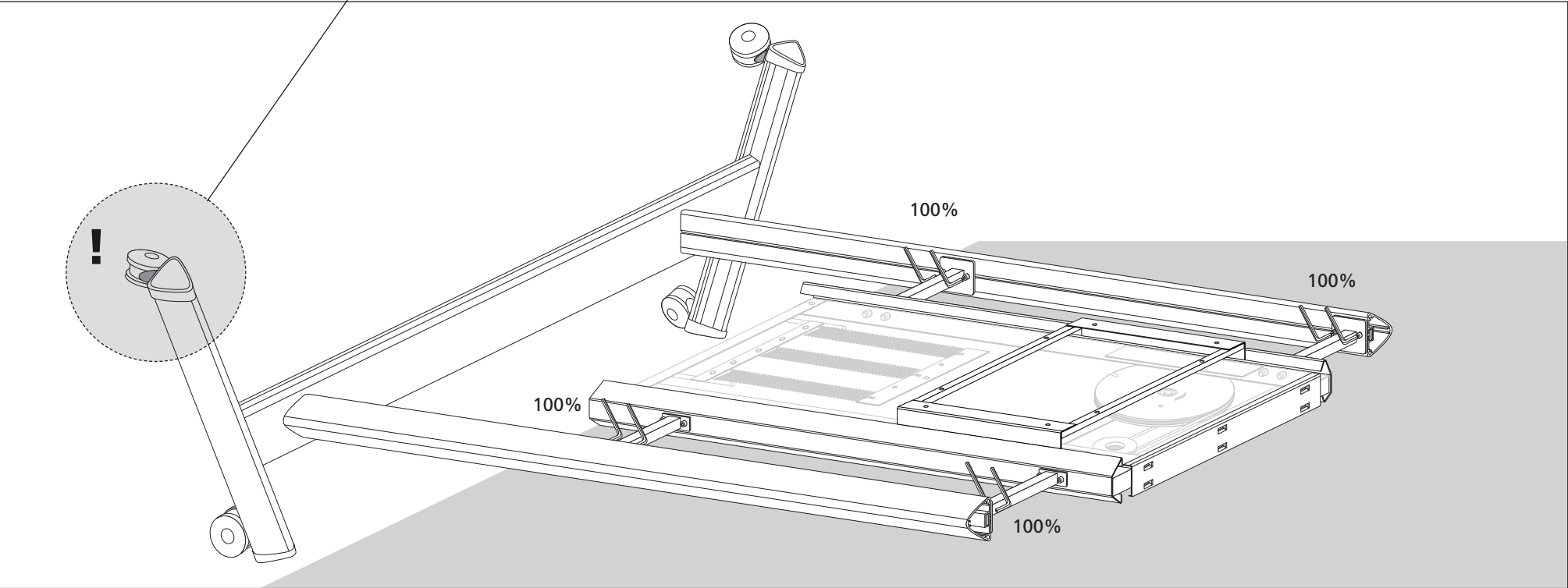
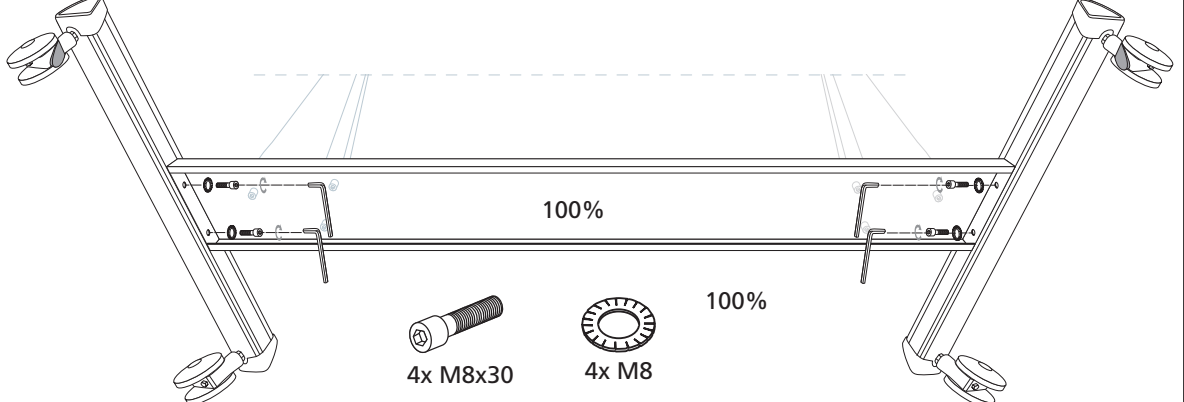
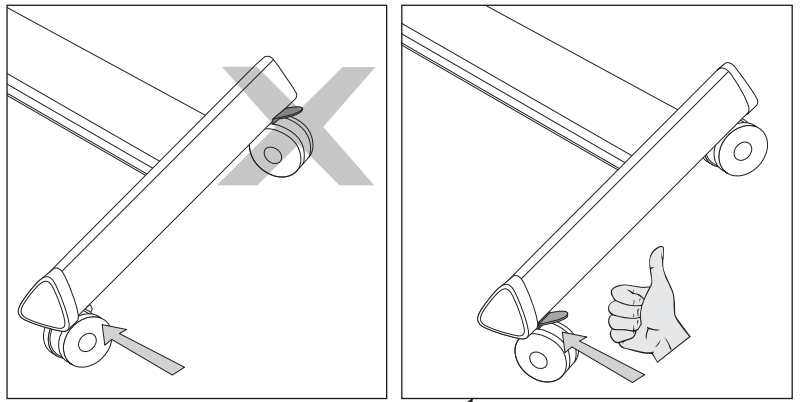

# MOUNTING INSTRUCTION

Mobile height adjustable stand for PROFESSIONAL e-Board

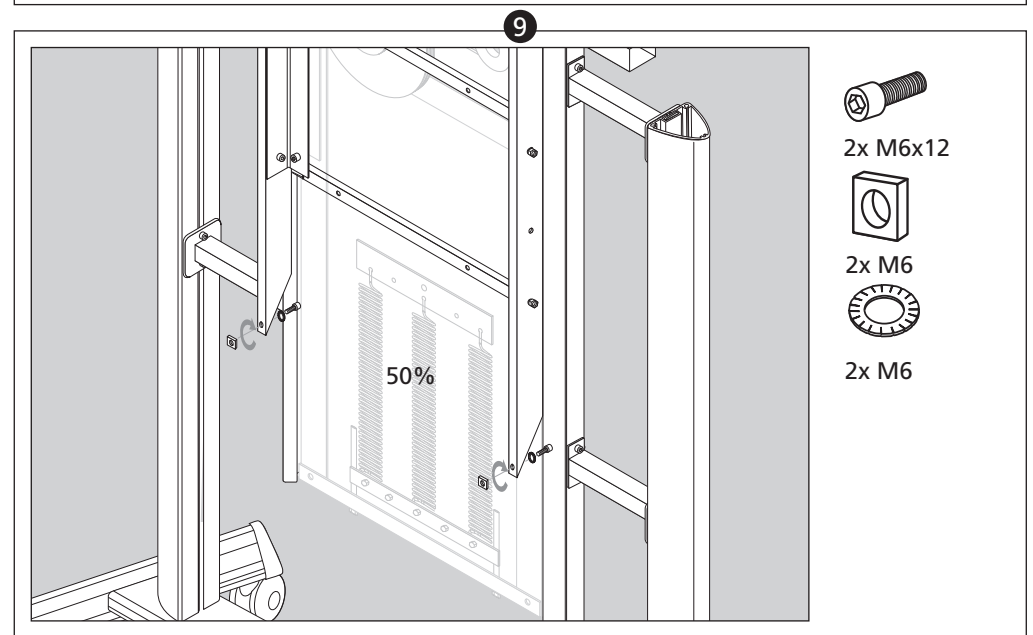
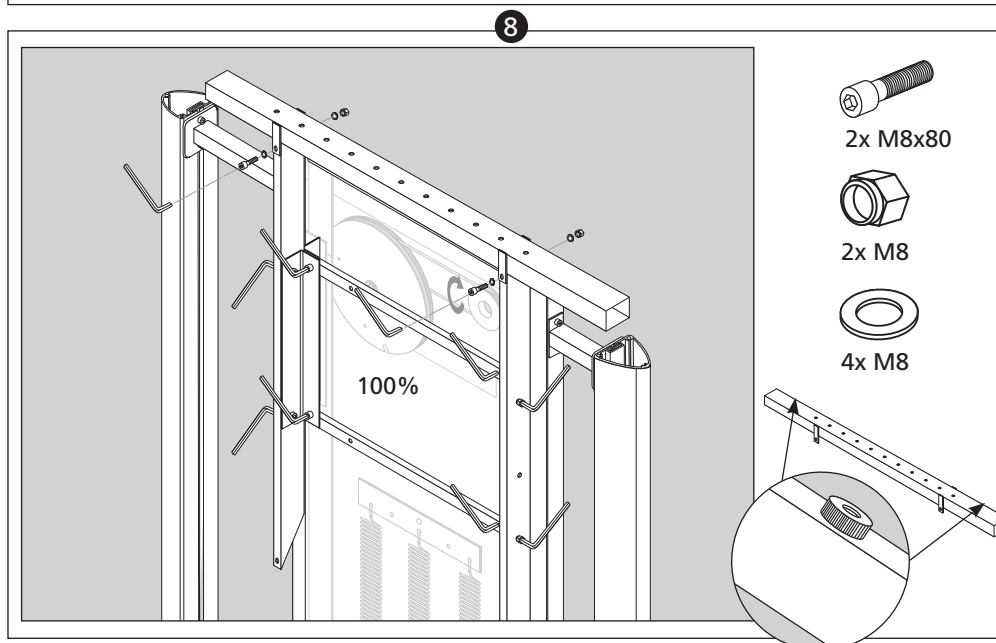
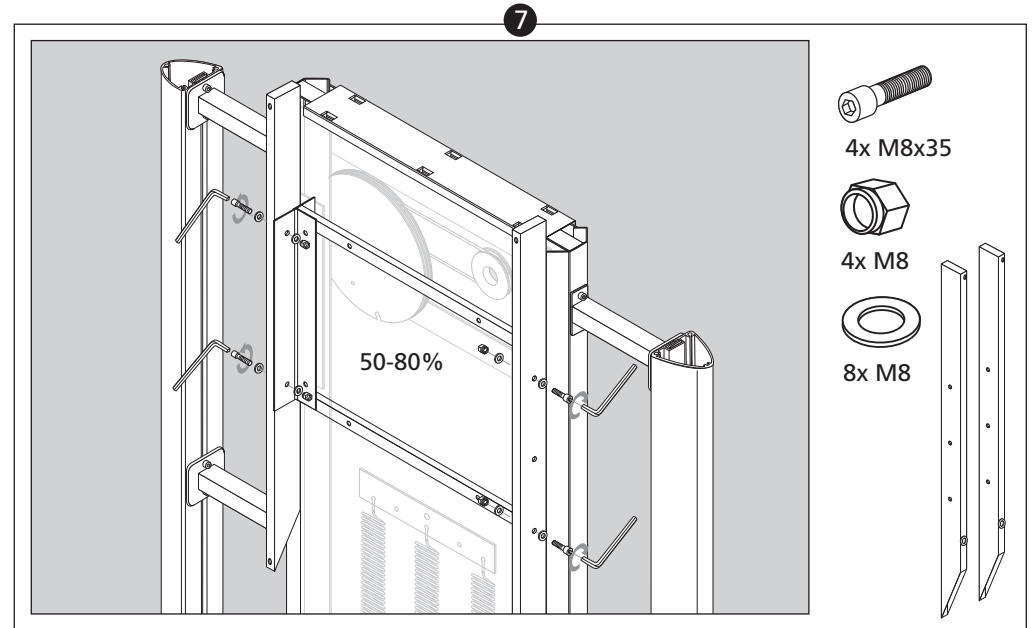
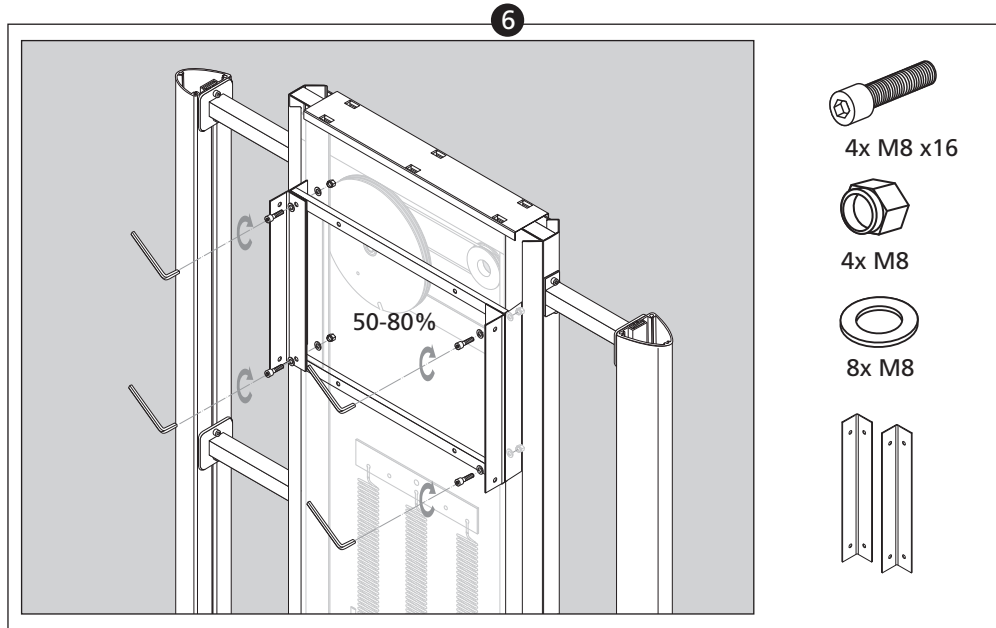

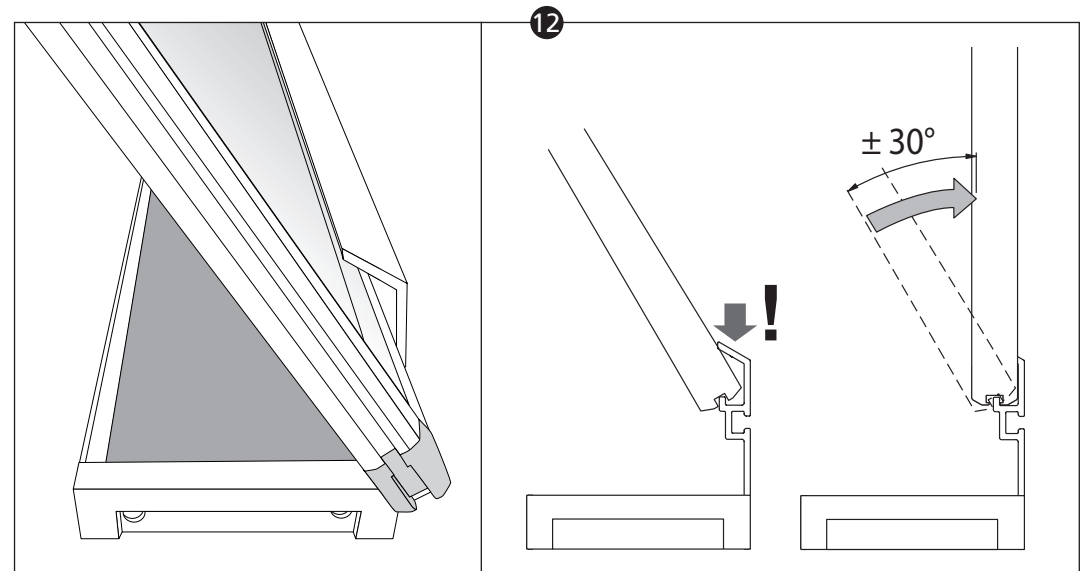
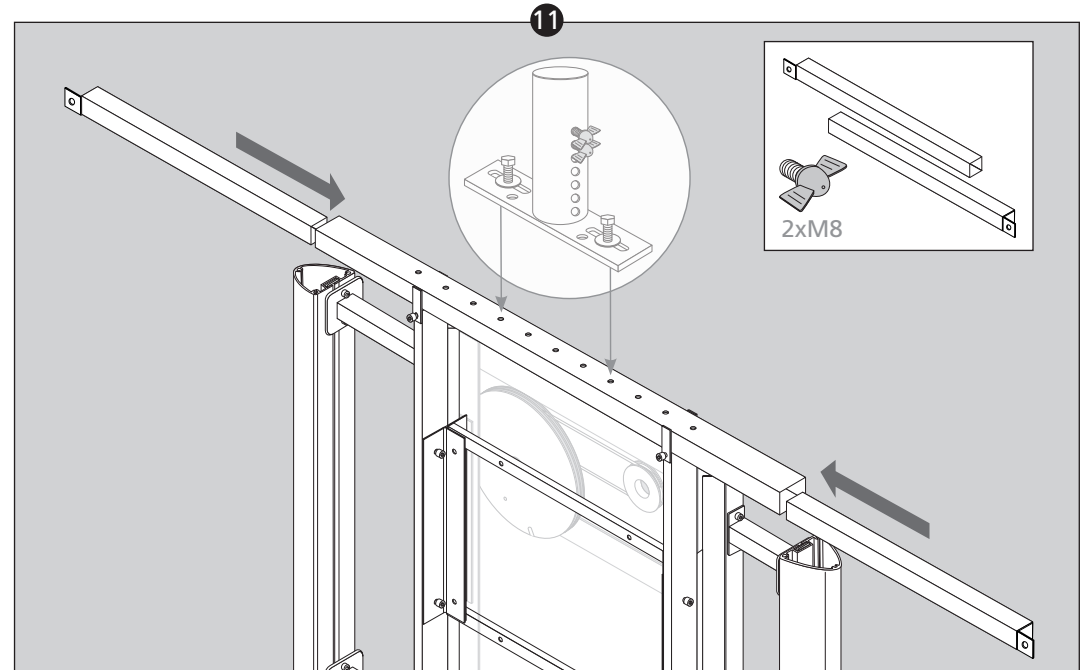
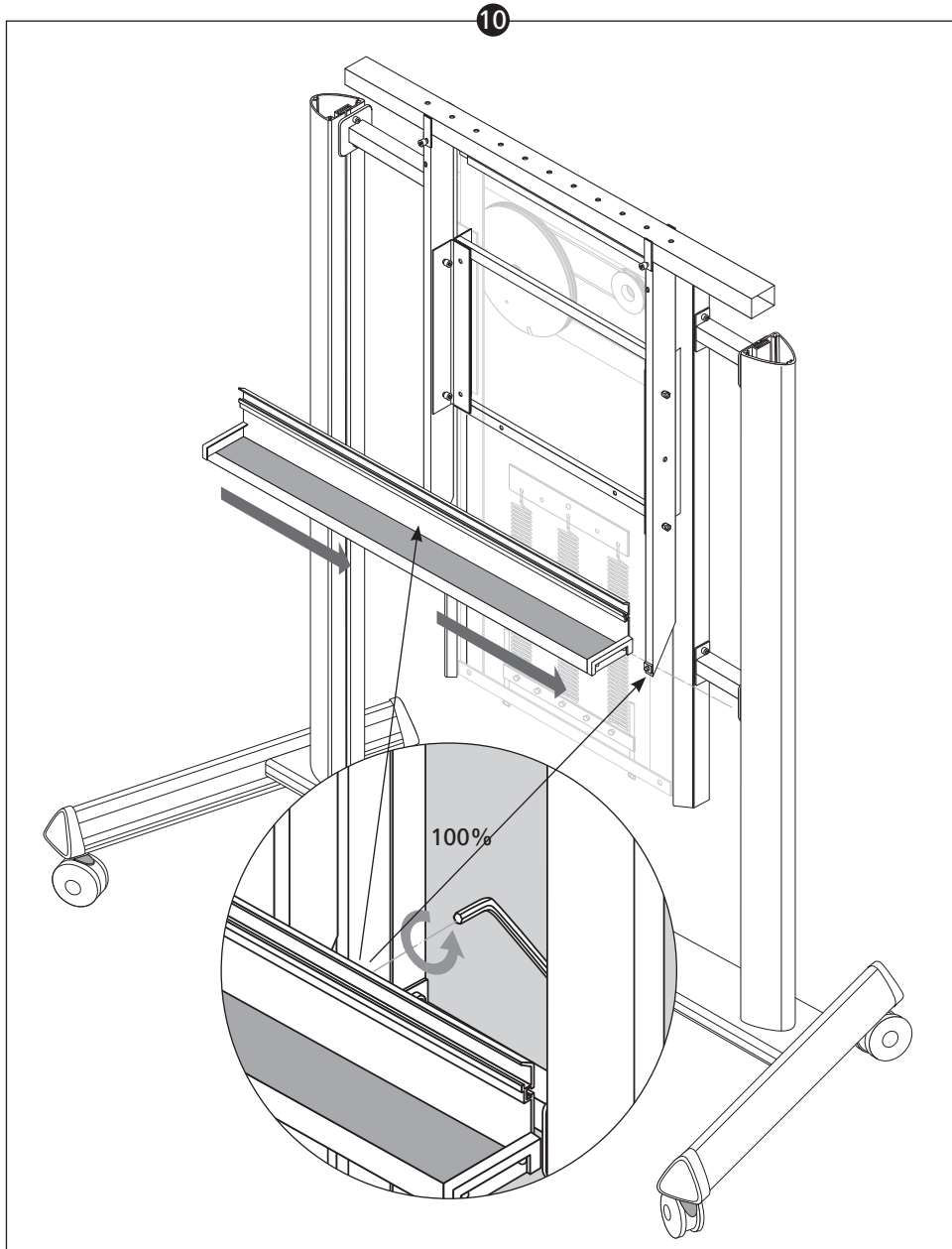

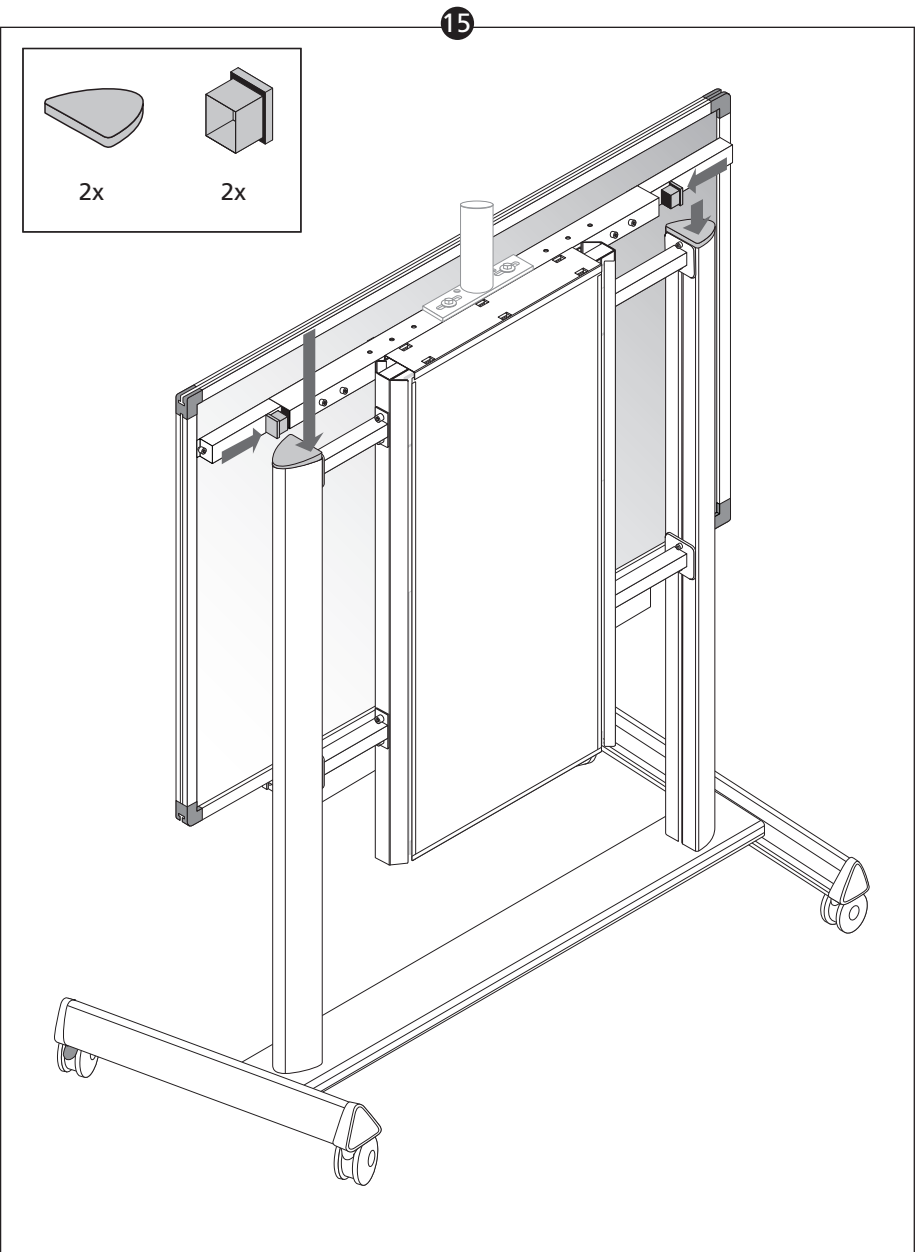
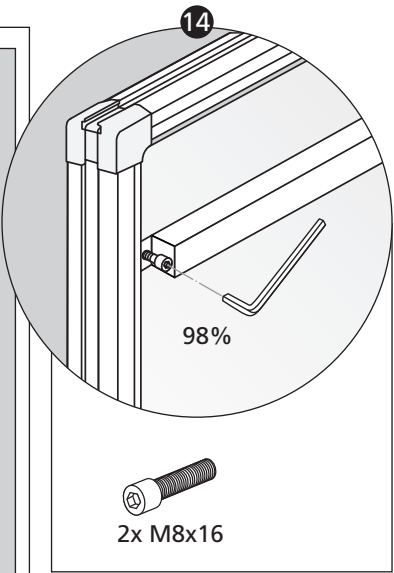
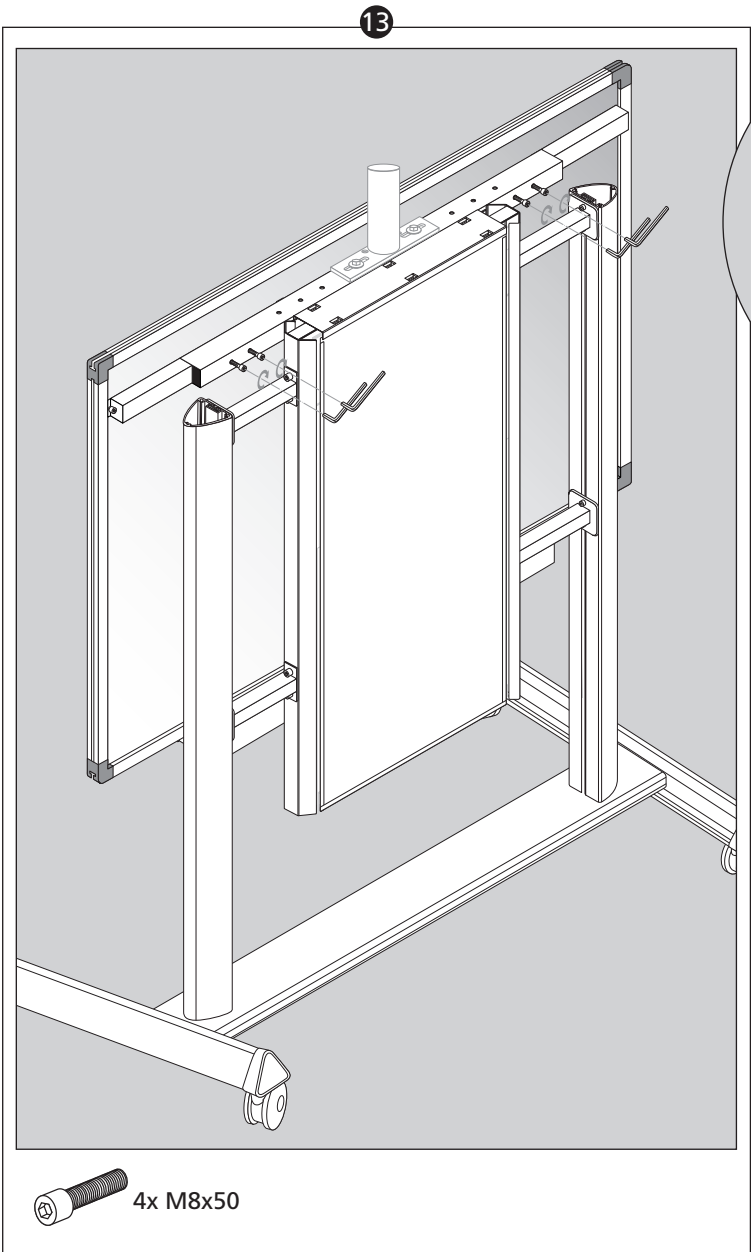



# MOUNTING INSTRUCTION

Mobile height adjustable stand for PROFESSIONAL e-Board

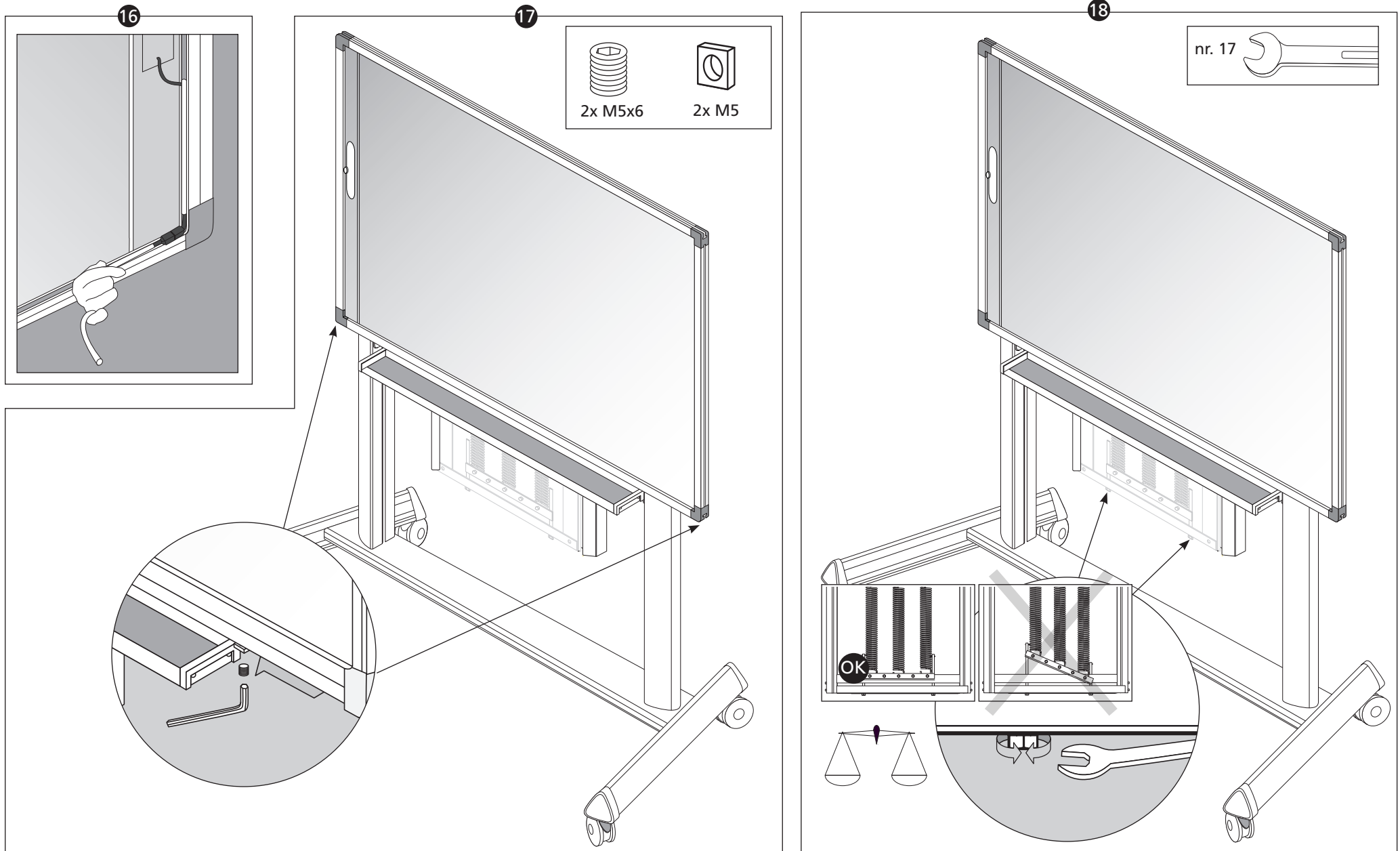

19

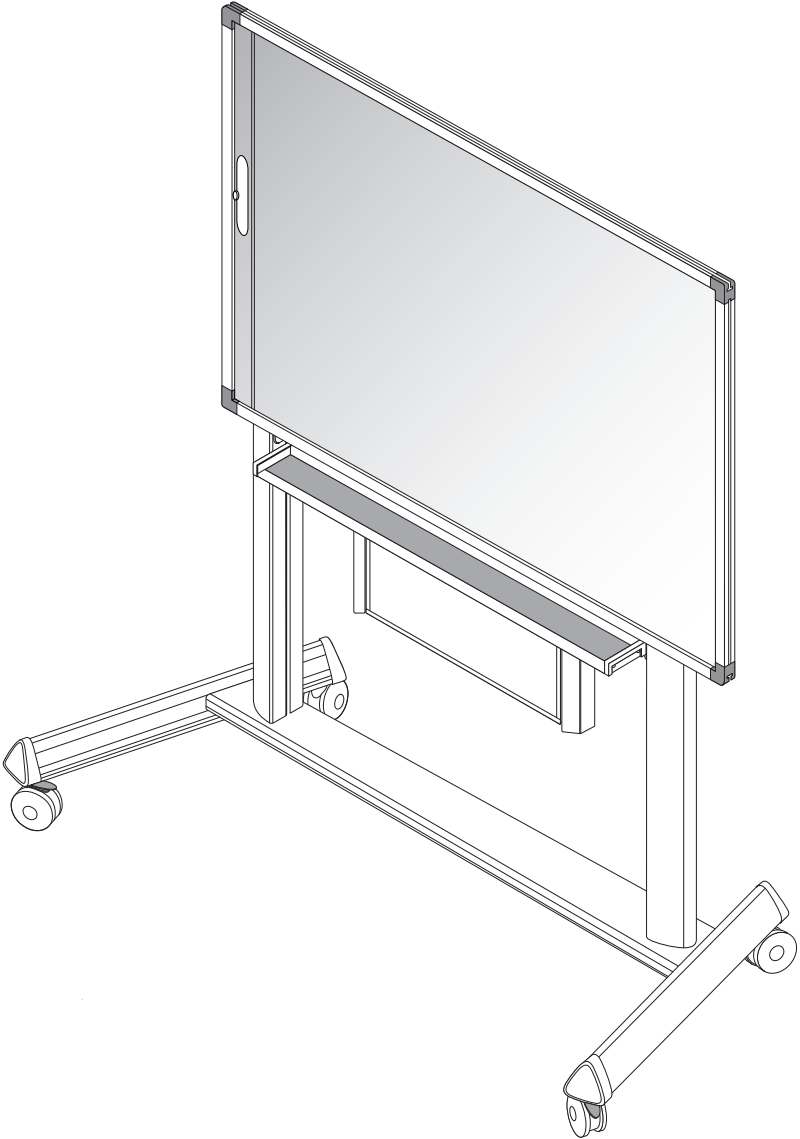
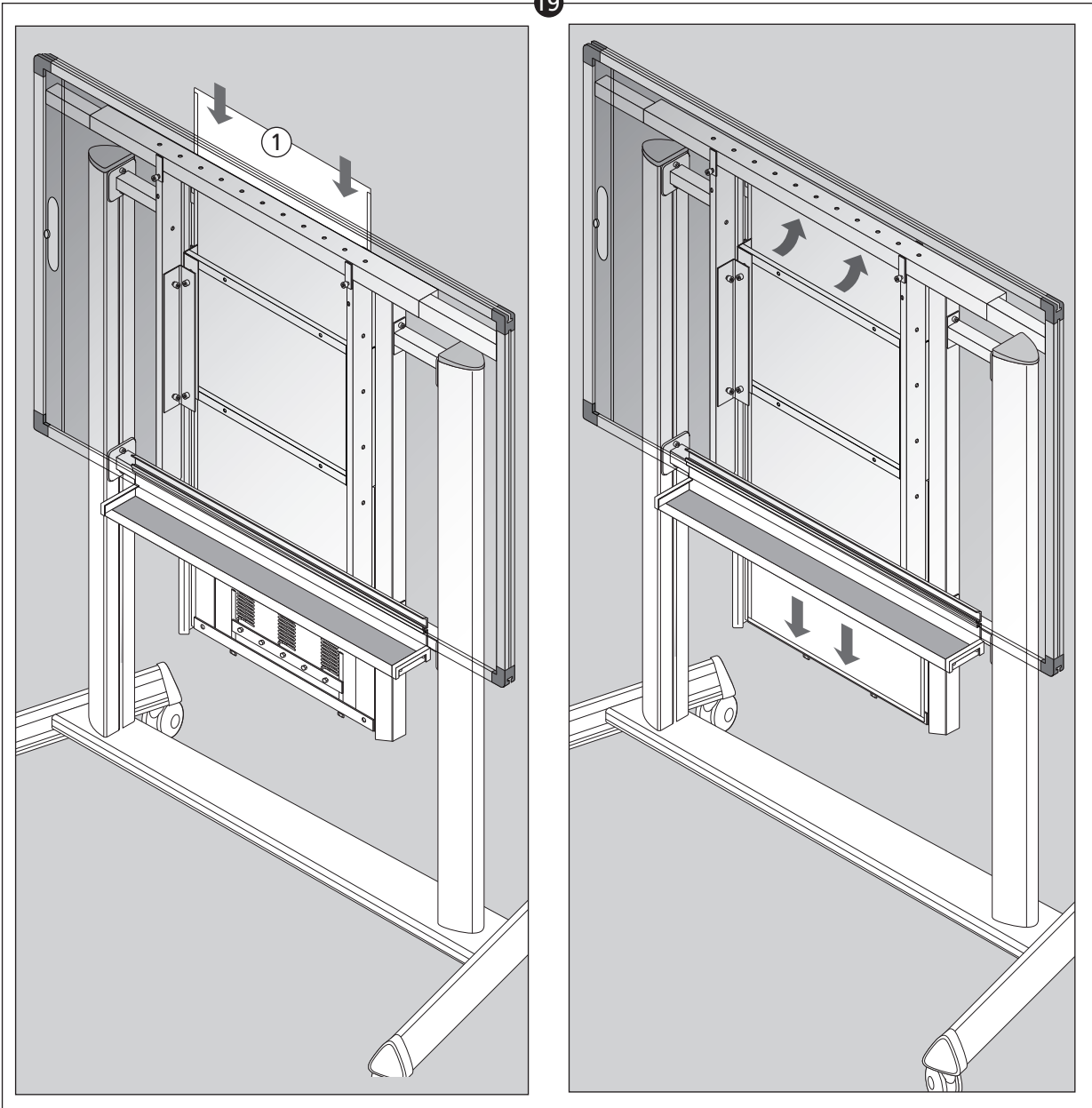

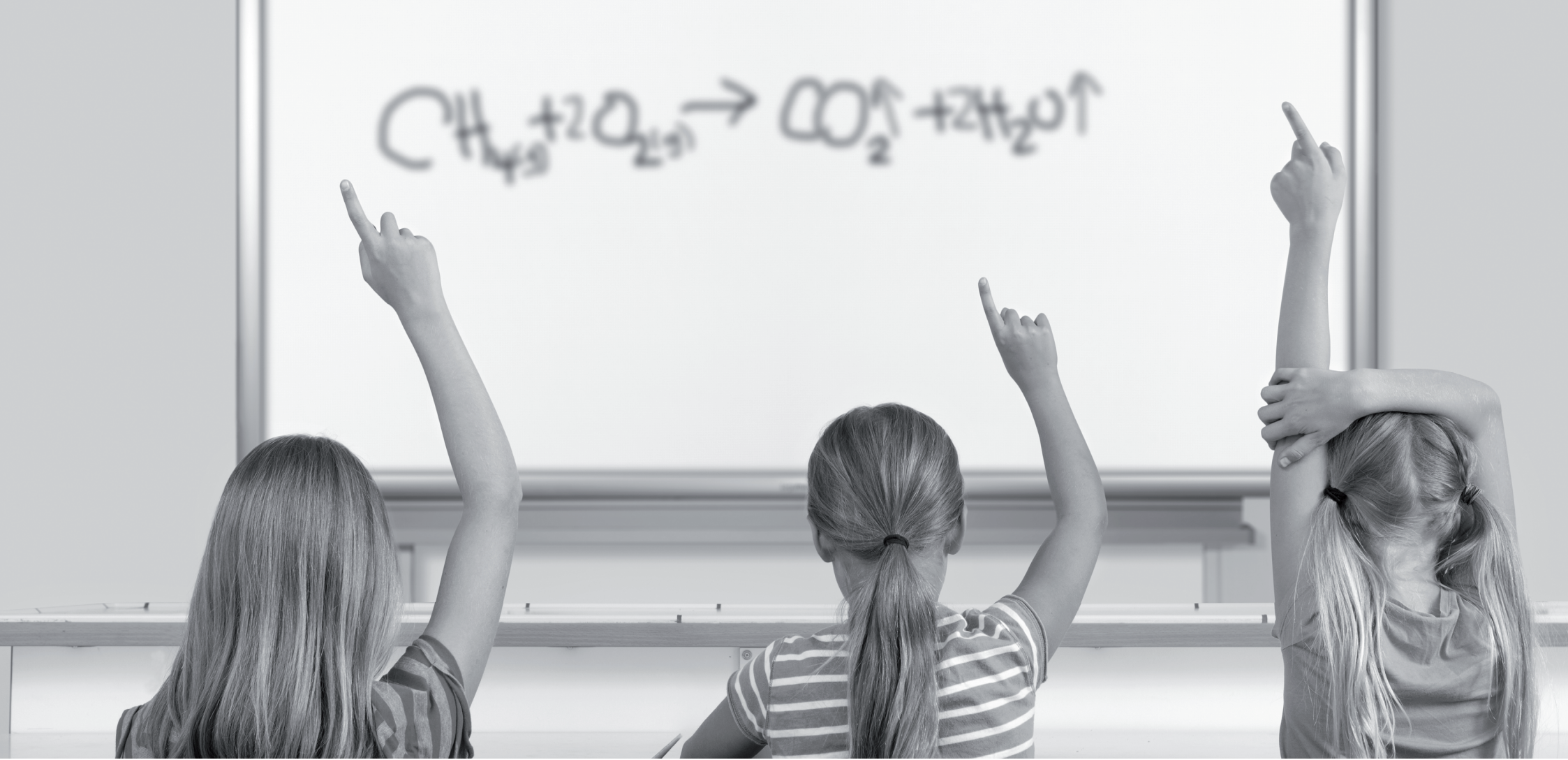

We make communication visible

**Legamaster** 

Legamaster International B.V.  
Postbus 111  
7240 AC Lochem  
tel.: (+31) (0)573-713000  
fax.: (+31) (0)573-713001  
email: [info@legamaster.com](mailto:info@legamaster.com)  
internet: [www.e-legamaster.com](http://www.e-legamaster.com)

857586000-2

Legamaster, brand of the edding group

